

Valves for Cryogenic Service

Type 01321 - Globe Valve



Cryogenic-Globe and Globe/Check Valves, PN50 (DN100=PN40, DN150=PN25)

Stainless steel body and bronze topwork
 "live loaded" gland packing
 "cleaned and degreased for oxygen service"

Part No. 01321.X.001* (H = 270mm)

Part No. 01321.X.002* (H = 370mm)

Part No. 01321.X.501* (H = 270mm) Globe/Check Valve

Part No. 01321.X.502* (H = 370mm) Globe/Check Valve

*Butt weld connection for stainless steel pipes acc. to DIN EN ISO 1127 or ASTM A312

Part No. 01321.X.0014 (H = 270mm)

Part No. 01321.X.0024 (H = 370mm)

Part No. 01321.X.5014 (H = 270mm) Globe/Check Valve

Part No. 01321.X.5024 (H = 370mm) Globe/Check Valve

Socket weld connection for stainless steel pipes acc. to DIN EN ISO 1127 and ASTM A312

Available options - on request only:

- Welded stainless steel stubs acc. to DIN EN ISO 1127 or ASTM A312 - length FF + 150mm
- Extension H up to 900mm
- Valve with control disc (tapered design)



Applications:

Approved for air gases, vapours and cryogenic liquefied gases incl. LNG.
 Working temperature: -196°C / -321°F (77K) up to +120°C / +248°F (393K)

Materials	DIN EN	ASTM
1 Body	1.4308	A 351 CF8
2 Valve seal up to DN50	PTFE / Carbon filled (25%)	
2a Valve seal from DN65	PTFE	
3 Disc	CW614N	B 283 UNS C38500
4 Bonnet gasket	PTFE	
5 Headpiece	CC493K	B 505 UNS C93200
6 Bolts	1.4301/A2	A 194 B8
7 Elongation tube	1.4541	A 213 TP 321
8 Stem	1.4301	A 276 Grade 304
9 Gland packing	Graphite / PTFE	
10 Gland nut	CW614N	B 283 UNS C38500
11 Handwheel	Aluminium alloy	
12 Spring	CW452K	B 103 UNS C51900

Standard marking acc. to Pressure Equipment Directive 97/23/EG (PED).

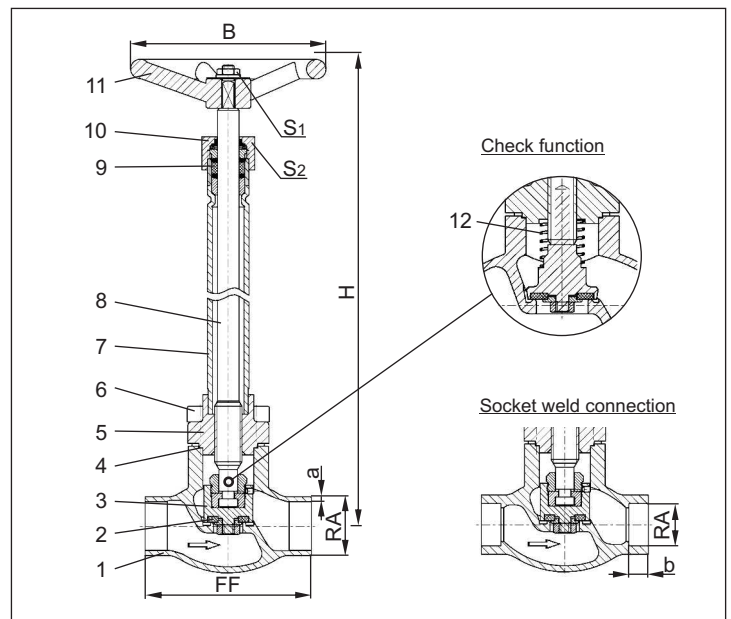

Type 01321 – Standard	Technical data	Nominal size													
		DN	10	15	15	20	25	32	40	40	50	65	80	100	150
Dimension code	.X.	1012	1517	1521	2026	2533	3238	4042	4048	5060	657x	8088	0114	0168	
Face-to-face dimension	FF	70	85	85	100	115	115	130	130	155	205	245	280	400	
Height	H	270 mm or 370 mm										400	400	400	420
Outside pipe-Ø EN ISO 1127	RA	12.0	17.2	21.3	26.9	33.7	38.0	42.4	48.3	60.3	76.1	88.9	114.3	168.3	
Wall thickness pipe EN ISO 1127	a	1.0	1.6	2.0	2.0	2.0	2.0	2.0	2.0	2.0	2.6	3.2	6.0	7.1	
Outside pipe-Ø ASTM A312	RA	13.72	17.15	21.34	26.67	33.40	-	42.16	48.26	60.33	73.03	88.90	114.3	168.3	
Wall thickness pipe ASTM A312	a	S10	S40	S10	S10	S10	-	S10	S10	S10	S40	S10	S40	S40	
Socket depth	b	6	10	10	13	13	-	13	13	16	16	16	20	20	
Handwheel-Ø	B	80	100	100	100	100	125	125	125	125	200	250	315	360	
Wrench size across flats	S ₁	10	10	10	10	10	13	13	13	13	13	13	13	19	
Wrench size across flats	S ₂	30	30	30	30	30	36	36	36	36	36	36	41	41	
Weight	ca. kg	1.4	1.65	1.7	2.1	2.4	3.3	4.7	4.7	7.2	12.7	17.0	24.5	54.0	
Kvs – Value	m ³ /h	1.6	3.8	4.3	6.7	11.5	14.0	20.6	22.6	37.1	71.1	104.0	170.0	350.0	
Cv – Value	gal /min	1.9	4.4	5.0	7.8	13.4	16.2	23.9	26.3	43.2	82.7	120.9	195.2	401.8	

Dimensions in mm.